



# KELLER

## INTRINSICALLY SAFE INTELLIGENT MANOMETER FOR HAZARDOUS APPLICATIONS, 94/9/CE (ATEX 100a)



### MANO GAUGE Ei MANO RECORD Ei

This is a highly accurate microprocessor-controlled pressure measuring instrument. SensoBrain™, a KELLER-designed low power signal processor, transmits the signals of the pressure- and temperature sensor to the microprocessor, which digitally compensates the sensor data. This mathematical modelling of the pressure sensor virtually eliminates all errors over a wide temperature range.

#### MANO GAUGE (Basic Version)

Display of: Pressure, Pressure Unit, Temperature, Elapsed Time

Alternative: Pressure, Pressure Unit, Max.- and Min. Value

All functions are executed with the front key of the instrument. It allows the display to be set to zero and to change the measuring cycle for prolonged battery life.

#### MANO RECORD (MANO GAUGE plus data recording)

Based on the MANO GAUGE, the MANO RECORD records and stores the measured values. The front key is used to select which data shall be displayed and stored, and to set the recording interval and the number of readings (memory for 900). The read-out of the stored data to a PC is via RS 232 serial interface (Logger Software and K101 cable available as option).

**The data transfer takes place via the serial interface on the PC and must not be done in intrinsic area!**

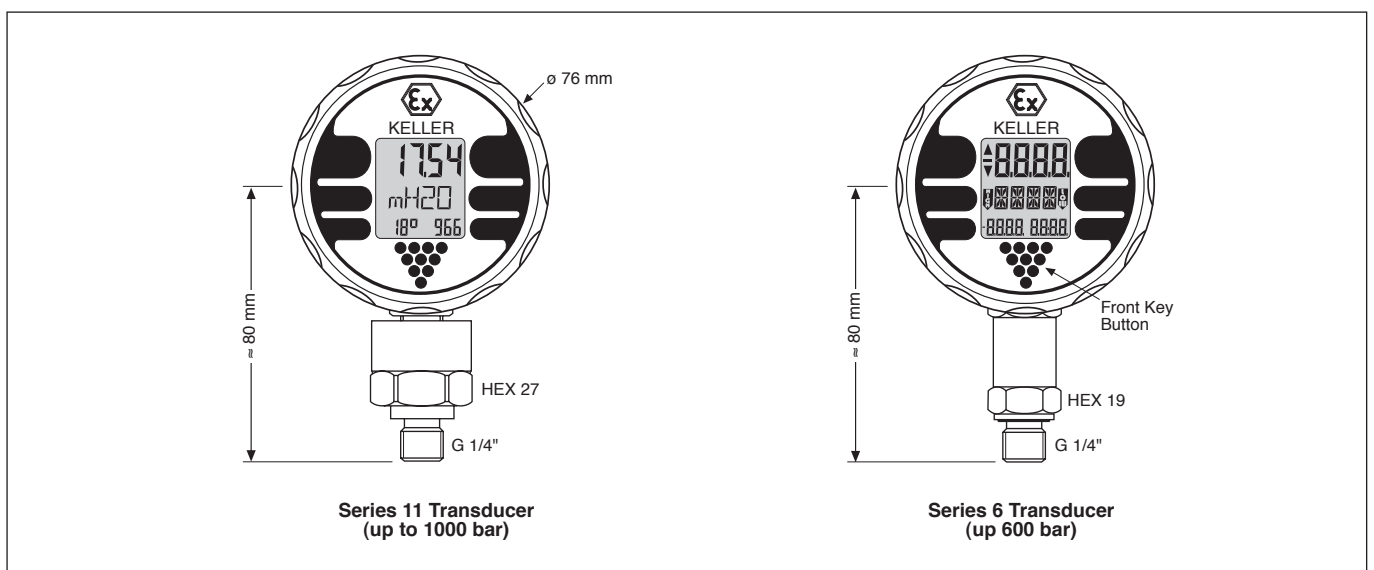
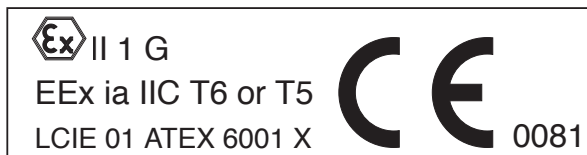
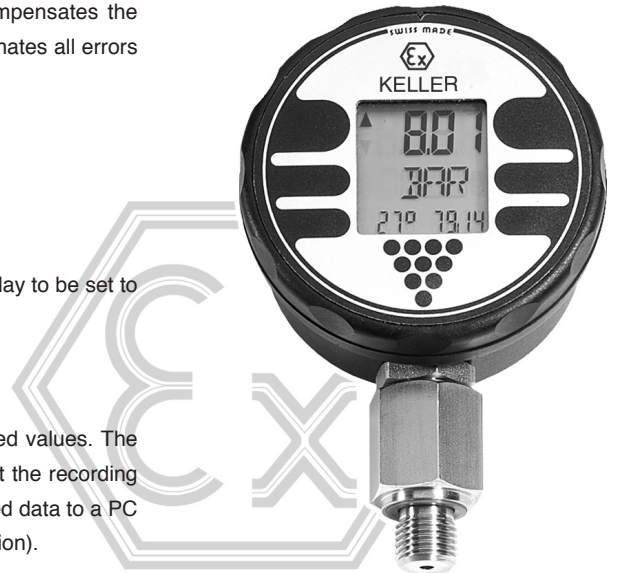

Subject to alterations

3/02

KELLER AG für Druckmesstechnik  
KELLER Gesellschaft für Druckmesstechnik mbH

St. Gallerstrasse 119  
Schwarzwaldstrasse 17

CH-8404 Winterthur  
D-79798 Jestetten

Tel. 052 - 235 25 25  
Tel. 07745 - 9214 - 0

Fax 052 - 235 25 00  
Fax 07745 - 9214 - 50



# KELLER

## SPECIFICATIONS

### MANO GAUGE / MANO RECORD

Vented Gauge or Absolute		Sealed Gauge or Absolute	
Range	Resolution	Range	Resolution
1000 mbar	0,3 mbar	100 bar	0,03 bar
-1...2 bar	1 mbar	300 bar	0,1 bar
10 bar	3 mbar	600 bar	0,2 bar
30 bar	10 mbar	1000 bar	0,3 bar

In MANO GAUGE and MANO RECORD the measuring ranges are divided by 12 bit or 3000 points.

The resolution is determined by the measuring range and the number of measuring points.

All instruments can be supplied with 8 bit, 10 bit or 12 bit resolution.

#### • Specific Characteristics

Total Accuracy <sup>(1)</sup>		
Range 0...50°C		± 0,1% typ. ± 0,2% max.
Measuring Interval	sec	≥ 1 (programmable)

<sup>(1)</sup> Includes linearity, repeatability, hysteresis, temperature and resolution of the display

#### • Environmental Characteristics

Operating Temperature	°C	- 10...60
Compensated Range <sup>(2)</sup>	°C	0...50
Storage Temperature	°C	- 30...80
Display <sup>(2)</sup>	°C	0...50

<sup>(2)</sup> others upon request

#### • Electrical Characteristics

Supply	2 Lithium-Batteries 3 V (included)
Battery-Life	> 200 days at continuous operation
Output Signal:	
Numerical	RS 232 (MANO RECORD)

#### • Mechanical Characteristics

Manometer Housing	Faradex
Transducer	See data sheet of transducer
Total Weight	approx. 250 g
Pressure Connection	See data sheet of transducer
Protection	IP 65

#### • Options (on request)

- External Transducer (max. 10 m cable) / - Special Programs / - Logger Software and K101 Cable

#### • Special conditions for safe use in hazardous applications

The Intelligent Manometer is an "intrinsically safe apparatus"; it can be mounted in explosive atmospheres. When the apparatus is mounted in dangerous area, equipment must not be connected to the terminal block.

When the apparatus is mounted in non dangerous area, the terminal block can be only connected to a certified intrinsically safe equipment which the electrical parameters do not exceed the following values:

$$U \leq 6,5 \text{ V} \quad I \leq 100 \text{ mA}$$

Operating ambient temperature:

$$T5: -10 \text{ °C to } +80 \text{ °C} \quad T6: -10 \text{ °C to } +65 \text{ °C}$$

#### • Guidelines

The certificate for these instruments is registered at the LCIE in France under the following number: LCIE 01 ATEX 6001 X.

These instruments meet the basic requirements which are established in the guidelines of the European Community:

- Directive EMC 89/336/EEC
- Directive ATEX 94/9/CE

#### LOGGER

The Logger-Software allows the read-out of the stored data from the MANO RECORD. The data transfer takes place via the serial interface on the PC and **must not be done in intrinsic area!**

The MANO RECORD is connected through a cable K101 (supplied with Logger software).

The LOGGER-software offers many further processing possibilities of the read-out data, and meets all the requirements of modern Windows-Software:

- Graphical Display
- Tabulated Display
- Export into other Windows-Programs
- Storage into Files

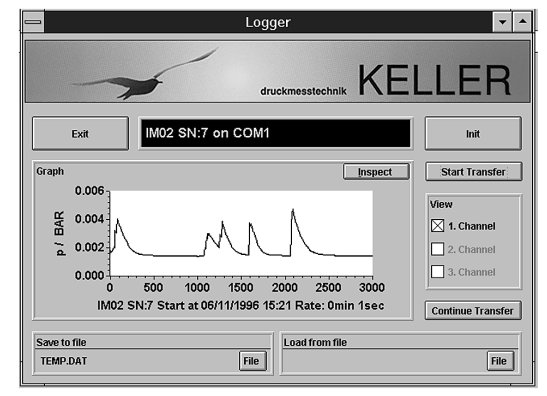

Subject to alterations

3/02

**KELLER AG für Druckmesstechnik**  
KELLER Gesellschaft für Druckmesstechnik mbH

St. Gallerstrasse 119  
Schwarzwaldstrasse 17

CH-8404 Winterthur  
D-79798 Jestetten

Tel. 052 - 235 25 25  
Tel. 07745 - 9214 - 0

Fax 052 - 235 25 00  
Fax 07745 - 9214 - 50